



TECHNICAL MANUAL

Revision 4, August 2002

IMPORTANT: Read these instructions before installing, operating, or servicing this system

VOYAGER[®] 550

BATTERY AND ELECTRIC VERSION 2 AND 4 FUNCTION

CEILING LIFT SYSTEM

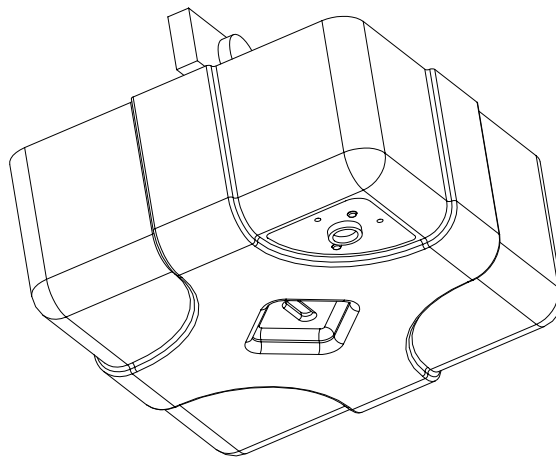

DO NOT DESTROY

BHM Medical Inc. designs and manufactures quality engineered patient lifting equipment for the care of the disabled in hospitals, nursing homes and home care.

Please take the time to read the entire manual, including the section on Safety Instructions and Warnings. It contains important information that will allow you to take advantage of all the characteristics of your BHM patient lift.

BHM Medical Inc. Credentials

- FDA Registration # 9681684
- CE mark (European Union Listing)
- Global operations for in-warranty and out-of-warranty service support for Voyager Series lift.
- Each finished Voyager Series is individually tested in our laboratory.
- Lifting capacity ranges from 190-360 kg (420-800 lbs.). Engineering safety factor exceeds European Standards.
- Complete range of patient lift slings and supports designed and manufactured by BHM Medical Inc. using medical quality materials and fabrics.
- ISO 9001
- Voyager is a registered trademark of BHM Medical inc.

APPROVALS:

CSA 601.1
UL 2601.1
EN 60601.1
EN ISO 10535 (Lifting device) SGS
UK Test Report: DUR22107/AC/OO

Note: BHM Medical is constantly improving its products. For this reason, it may be possible to encounter a modification of product without revision of this guide.

Thank you for trusting your BHM Medical Partners.



How to contact us:

North America:

*BHM Medical Inc.
2001 Tanguay Street
Magog (Quebec)
Canada J1X 5Y5*

Phone: (819) 868-0441

*🕒 service calls during business hours - extension #109
(8:00-12:00 and 1:00-5:00 p.m. E.S.T.)*

*🕒 service calls outside regular business hours
extension #6199 (you must press the pound key)*

Fax: (819) 868-2249

Web site: www.bhm-medical.com

E-mail: bhm@bhm-medical.com

INTRODUCTION	4
How to use this Manual.....	4
Equipment Identification.....	4
Receipt of Equipment.....	4
Key to Symbols	4
DESCRIPTION OF EQUIPMENT	7
Lift Unit.....	7
What's included.....	7
Parts Description.....	7
Dimensions	7
OPERATION	8
How to use Voyager 550.....	8
Emergency Stop	9
Emergency Lowering Feature.....	9
Battery Information.....	10
Charger Specification:.....	11
MAINTENANCE	11
Daily Check List	11
Inspection and Cleaning	11
Strap Inspection	11
Lubrication	12
Handling and Storage	12
Battery Replacement	12
Strap Replacement	13
Drum Replacement.....	14
Horizontal Motor Replacement	15
Vertical Motor Replacement.....	16
Limit Switch Replacement.....	16
Limit Switch Rod Replacement.....	17
Maintenance Inspection Checklist	18
TROUBLESHOOTING	20
PARTS LIST.....	22
ACCESSORIES	28
WARRANTY.....	29

INTRODUCTION

How to use this Manual



DO NOT ATTEMPT TO USE THIS EQUIPMENT WITHOUT UNDERSTANDING THIS MANUAL.

To ensure safe operation, read the entire manual carefully, especially the section on “Safety Instructions and Warnings”, before installing, operating, or servicing this equipment.

If anything is not completely understood, please contact your supplier for more details. Failure to comply with warnings in this manual may result in injury.

Keep this manual with the lift and refer to it as required. Contents of this manual are subject to change without prior notice to users.

Throughout this manual, the following symbols may appear. Pay particular attention to the information provided under these headings. These special annotations are easily recognised as follows:



WARNING: this symbol is intended to alert the user to hazards or unsafe practices, which could result in serious bodily harm.



CAUTION: this symbol is intended to alert the user of the presence of important operating and maintenance instructions, which could prevent product damage or possible personal injury.



NOTE: this symbol offers helpful information concerning certain operating procedures.

Additional copies of this manual can be purchased by contacting your supplier. Include the User Manual product number and equipment identification numbers.

Equipment Identification

The unit's identification number (specification, model, serial number) appears on a silver nameplate attached to the back of base.

Receipt of Equipment

Upon receipt of the equipment, verify it against the packing list to ensure it is complete and inspect the equipment for possible damage due to shipping. If there is any damage, DO NOT USE the equipment and notify the carrier immediately to file a claim. Provide complete information concerning damage claims or shipping errors to your supplier. Include all equipment identification numbers and group part numbers (if any) as described above along with a full description of damaged parts.

Key to Symbols

The following symbols are used on lifter's attachment labels:

CE This symbol is required to be displayed on regulated products for sale in the European Market. It indicates that the product complies with applicable European Directives related to health, safety, environment and consumer protection.

SWL Safe Working Load represents the maximum load the lifter is rated for safe operation.

The following symbols are used on sling labels and related to washing instructions:

 Maximum washing temperature 60°C (140°F) permanent cycle.

 Do not use bleach.

 Do not dry clean.

 Tumble dry low temperature.

 Do not iron.

Please refer to individual sling labels for complete instructions regarding washing and drying.

SAFETY INSTRUCTIONS AND WARNINGS

A. GENERAL

- **IMPORTANT – READ THESE INSTRUCTIONS CAREFULLY OR SERIOUS INJURY MAY RESULT.**
- **KEEP THESE INSTRUCTIONS AND THE KEY PROVIDED WITH THE LIFT AT ALL TIMES.**
- **READ OPERATION AND MAINTENANCE INSTRUCTIONS IN THIS MANUAL BEFORE INSTALLING, OPERATING, OR SERVICING THIS EQUIPMENT.**
- **An authorized contractor or installer must install BHM Medical ceiling lifts.**
- **YOUR LIFT is for transferring patients only. Do not use the lift for any other purpose.**
- **ALWAYS carry out the daily checklist before using the lift.**
- **BHM Medical ceiling lifts are specifically designed for BHM Medical ceiling rail systems, slings and accessories. Slings and accessories designed by any other manufacturer are prohibited and will void BHM Medical's warranty. Use only BHM Medical slings and accessories to maintain patient safety and product utility.**
- **BHM Medical ceiling lifts are intended to be used for patients within the specified weight limit indicated for the lift. Do not attempt to lift more than the weight limit indicated.**
- **Before attempting to transfer, the patient must be assessed by a qualified professional.**
- **BHM Medical ceiling lifts must be used by a caregiver with proper training to work with the patient to be transferred.**
- **ONLY trained and qualified caregivers should transfer a patient. DO NOT attempt to use the lift if you have not been properly trained to do so.**
- **ALWAYS be prepared before attempting to transfer a patient.**
- **DO NOT use a sling that is not recommended for the lift.**
- **NEVER use a damaged, torn or frayed sling.**
- **ALWAYS place the sling around the patient according to the instructions enclosed.**
- **FOLLOW lifting procedures outlined in this manual.**
- **USE all controls and safety features only according to the rules specified in this manual. Never attempt to force a control or button on the lift.**
- **DO NOT store the charger in a shower, bath or other areas with high humidity.**
- **DO NOT drop the patient lift or battery. Dropping the battery or lift may cause internal damage that is not easily seen. If lift is suspected to be damaged, take to an authorized technician for servicing.**
- **IMPORTANT: Keep all components of the lift clean and dry, and have electrical and mechanical safety checkpoints done as instructed in the Maintenance section of this manual.**
- **Replace any precautionary or instruction labels that cannot be easily read.**
- **Avoid violent shock during transportation.**

B. SHOCK PREVENTION

- **DO NOT touch or use a lift with bare conductors or a damaged power cord. Electrically live equipment can electrocute a patient. If the lift or charger has any exposed or damaged wires contact your local dealer immediately.**
- **DO NOT cut or remove the round grounding prong from any plug. All BHM lifts are equipped with three-prong plugs to protect from shock hazard or electrocution. Any two-prong electrical outlet must be replaced with a properly grounded three-prong outlet according to the National**

SAFETY INSTRUCTIONS AND WARNINGS

Electrical Code and local codes. It is the responsibility of the customer to have the work done by a qualified electrician.

- Do not splash or expose electric parts of the device to water or moisture.
- Check nameplate for voltage and cycle requirements. These requirements differ by country. Do not attempt to use the lift in an area that has a different voltage and cycle requirement.
- **DO NOT** attempt to expose, service or repair the lift, battery or charger. If any unit is malfunctioning, contact your local dealer.
- **READ** the battery and charger instructions thoroughly before using or storing them.

C. FIRE AND EXPLOSION PREVENTION

- Batteries may explode, leak and cause personal injury if not disposed of properly
 - Do not place or store the battery under direct sunlight or near a heat source
 - Do not dispose of in fire
 - Do not short the battery terminals
 - Do not incinerate
 - Flush with water if electrolyte (Acid) comes in contact with skin or eyes.
- Batteries must be recycled, disposed of according to local law regulations. When returning batteries, insulate their terminals with adhesive tape, etc. Otherwise, the residual electricity in used batteries may cause fire or explosion.



D. EQUIPMENT WARNING LABELS

- Inspect all precautionary labels on the equipment. Order and replace all labels that cannot be easily read.

DESCRIPTION OF EQUIPMENT

(Stainless steel model available for chlorinated area)

Lift Unit

The lift unit is a steel frame based system driven by a gear reduced high torque motor.

OPERATING FEATURES

- Lifting capacity: 250 kg (550 lbs.)
- Average weight: 22.73 kg (50 lbs.) battery included.
- Electronic soft-start and soft-stop motor control.
- Manual and electric emergency lowering device.
- Emergency brake (in case of mechanical failure). Operates on the same principle as a car safety belt mechanism.
- Emergency stopping device.
- Current limit for circuit protection in case of overload.
- Low battery disconnect system to protect batteries from being drained.
- Lifting speed: 6 cm/sec. (2.4 in./sec.).
- Horizontal displacement speed: 15 cm/sec. (6 in./sec.).
- Vertical axis motor: 24 VDC, 1/8HP.
- Horizontal axis motor: 24 VDC, 1/10 HP
- Strap length up 3.6 m (144 inches) tested for 1363.6 kg (3000 lbs.).
- CSA No. 601.1, UL No. 2601-1 and CE certifications.
- Respects EMI standards.
- ISO 10535.

What's included

ITEM	QTY
Voyager 550 lift	1
Battery (inside unit)	1
Integrated Charger Stopper	1
Rail Stopper	1
Handset	1
Carry bar	1
Power cord	1
Instruction manual	1
4 mm Allen Key	1

Parts Description

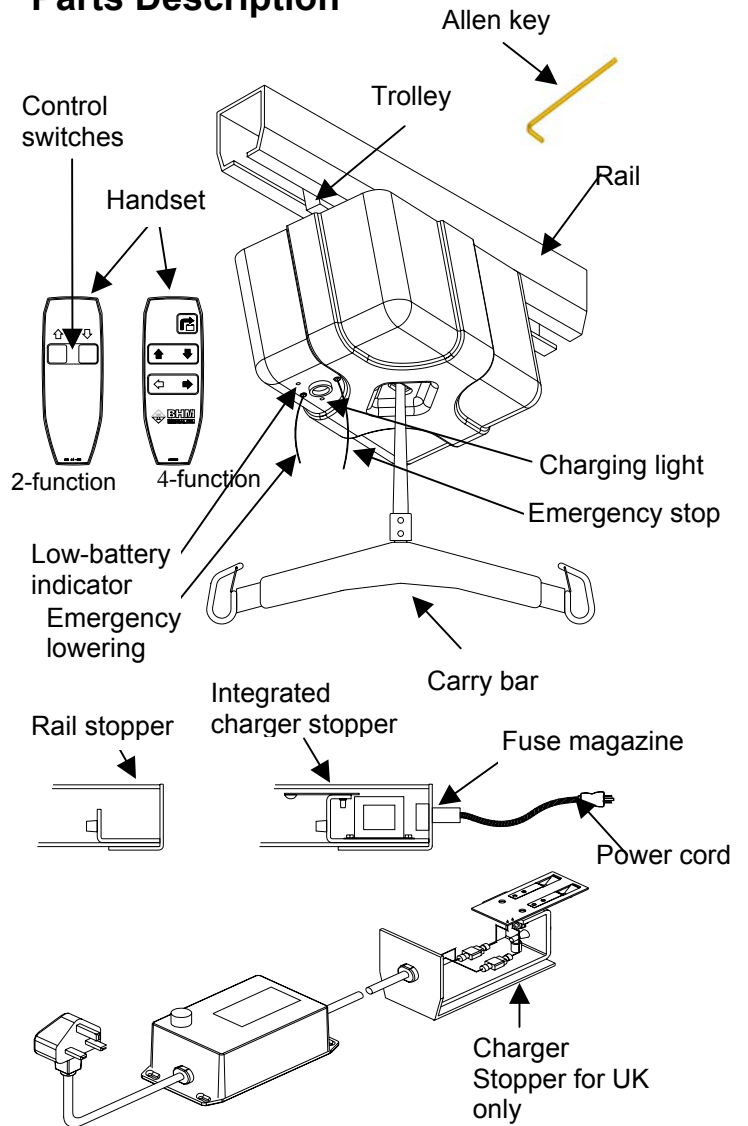

Dimensions

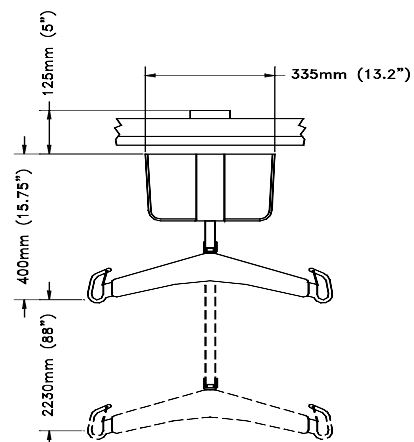

Allen key

OPERATION

How to use Voyager 550

 **READ "SAFETY INSTRUCTIONS AND WARNINGS" BEFORE ATTEMPTING TO USE THE VOYAGER 550.**

 **Unit will not lower or lift when in contact with the charger.**

1. Install the patient sling
Move the lift directly over the patient.
2. For two-function battery pull the unit manually directly over the patient or for four function battery, use the handset.





 **If the buttons do not operate on the handset, pull the red cord gently, once until you hear a "click"**

3. Using the handset  button, lower the carry bar below the patient's chin (to avoid the risk of facial contact caused by a sudden movement of the carry bar) before beginning to attach the sling straps. If lift will not operate – pull red cord once gently, until you hear a click.

 **Hold the lift carry bar with one hand at all times when near a patient.**

Note: In a lying down position, lower the carry bar near the thorax, then install the straps.

4. Attach the straps to the desired position.
5. Carefully observe the patient to ensure his/her safety as you press the control button .

 **BEFORE LIFTING THE PATIENT :**

1. Make sure that all straps are attached to the carry bar.
2. Make sure the patient is comfortable.
3. Make sure the sling is not caught on any obstruction (wheelchair brake or arm of chair).

If any of the above occur - lower the patient immediately and correct the problem.

Lift until the patient's buttock clears the arm supports or the top of the bath or bed before moving the patient. Guide the legs past any obstacle.

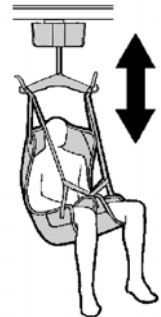

6. When the patient is located above the desired point of transfer, press the  button.
7. Use the handles on the back of the sling to position the patient when transferring into a chair. Hold the handles firmly as the sling lowers; the sling will tilt back to position the patient.
8. Once the patient is properly seated and the straps are loose, remove the sling from the lift.

 **Hold the lift carry bar with one hand at all times when near a patient.**

9. Slide the lift away from the patient.
10. When lift is no longer required:
2-function - gently return the unit to charger manually.
4-function - engage the automatic return to charger function by pressing .
11. Check the charging indicator light to ensure the charger is working.

Emergency Stop

(Red cord)

1. This can be activated at any time to stop the functioning of the lift.
2. To stop the lift in an emergency, pull the red cord once gently, you will hear a "click".

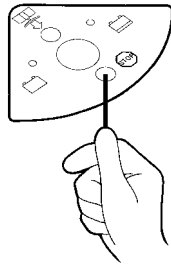



Do not pull the red cord forcefully. If cord pulled too forcefully, the lift may become inoperable.

3. When you initially receive your lift the emergency stop is in the "off" position. To activate the lift, pull the red cord once gently. To re-activate pull the red cord once gently, you will hear a "click".



Emergency Lowering Feature

(White cord)

In the event of an electrical or functional failure, the Voyager 550 has an emergency electrical and manual lowering feature.

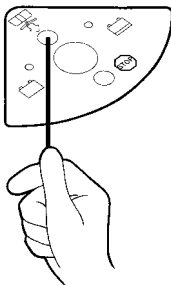



Only to be used in case of an emergency.

If the lift malfunctions when a patient is being transferred, the emergency lowering device provides a safe way of lowering the patient onto a chair or bed.

To operate the emergency lowering features:

Electrical Version

Move the patient over a bed or a chair, and then gently pull down on the white cord. **If this does not function then go to step 2.**

Manual Version:

Find the rubber stopper and label on the side of the lift.

VOYAGER 550

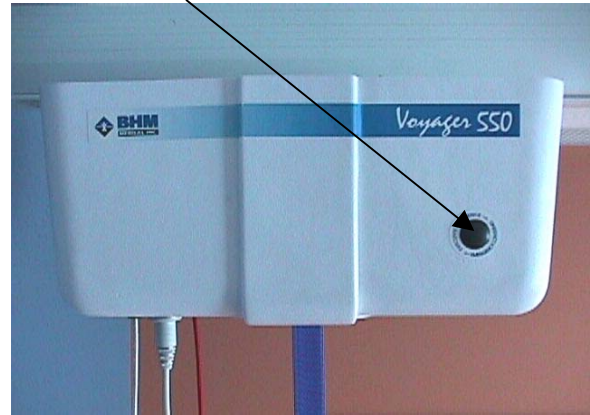

1. Pull the rubber stopper out of the Voyager casing – DO NOT DISCARD.

Use the Allen key provided with this manual, turn the key clockwise to lower the patient into a chair or bed. As the key turns the motor directly, each key turn will move the patient slightly.



To lower the patient more quickly, use a power drill with a 4 mm Allen key bit.

- Once the patient is lowered safely into a chair or bed, call a certified technician to have lift serviced.

Emergency Brake

- The emergency brake is made of a metal bar fixed to the drum. 
- In case of a chain, gear or motor breakage, the centrifugal force created would block the bar against the frame.

Frame with mechanical clips

- Supporting structure is welded and reinforced with metal clips. 

Battery Information

- 24 Vdc, 7 Ah rechargeable battery.
- Provides up to 150 transfers with load of 75 kg (165 pounds).

Life cycle (number of charging cycles) of the battery is largely dependent on the depth of discharge in each cycle. The more the battery is drained the shorter its life span. The life of the battery is also related to such factors as varying temperatures and rest periods between charge and discharge.

Graph 1: Number of recharges vs. Depth of discharge

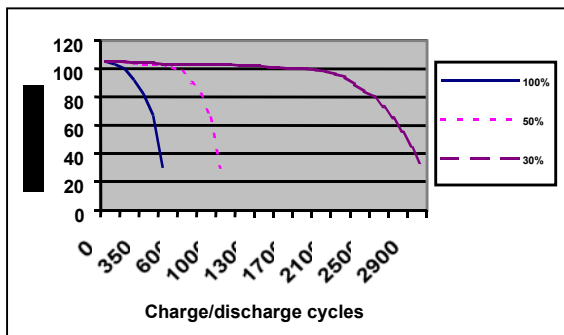

Graph 1 illustrates the relationship between discharging depth and expected battery life.

If you drain the battery until it beeps every time, you can expect the battery to fully charge only 600 times.



To prolong battery life – Return the lift to the charger WHENEVER THE LIFT IS NOT IN USE.

The battery will not overcharge.

BHM uses sealed lead-acid batteries. Contrary to nickel-cadmium, BHM batteries do not have any memory effect. Therefore, batteries should not be completely drained before recharge.

Graph 2: Number of lifts vs. Lift load

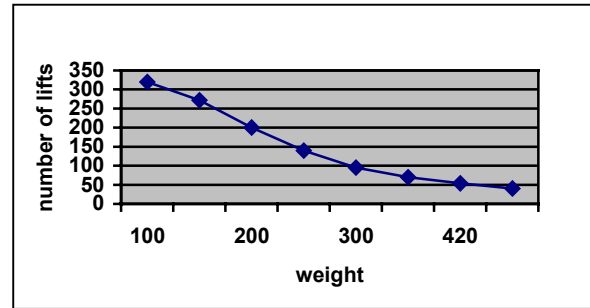

The graph above (Graph 2) illustrates the relationship between the load lifted and the number of lifts that can be done with one recharged battery.



Do not drain the battery excessively. This will dramatically reduce the battery life span.

If the low battery buzzer sounds and red light flashes, be sure to recharge the battery as soon as possible.

Charging the battery



DO NOT operate the charger unit with a damaged cord or if the unit has been dropped or damaged.

DO NOT forcibly bend the power cord or place a heavy object on it. This will damage the cord and may cause fire or electrical shock.

DO NOT pour liquid on or near the charger.



Do not place the unit in locations that are:

- Extremely hot
- Dusty or dirty
- Very humid
- Moving or vibrating

The recharging steps should be as follows:

For the 4-function, return to charge and press

the  button on the handset. The lift cannot return to charger with a 50-pound load.

For the 2 function, pull the lift gently over to the charger and ensure it is properly connected.

 **DO NOT SLIDE THE LIFT OVER TO THE CHARGER FORCEFULLY OR QUICKLY. THE CHARGER MAY BECOME DAMAGED.**

- The indicator light will illuminate red to green depending on the battery drain. If the light does not go on, check “Troubleshooting” section in this manual for assistance.
- If the battery is low, the light will show red or orange when you return the lift to the charger. The light will gradually turn to green when fully charged.

 **Whenever possible leave the lift on the charger when the lift is not in use. At minimum, charge the battery until the light is green before using it again. This will extend the life of the battery.**

Charger Specification:

- Hospital grade charger cord and plug.
- Charger input: 120 Vac, 60 Hz, 0.5 A. (North America) / 240 Vac, 50 Hz, 0.25 A (European).

MAINTENANCE

 **ALWAYS CARRY OUT THE DAILY CHECKLIST BEFORE EACH LIFT USE.**

Alterations made to the VOYAGER 550 by someone other than a certified technician may cause serious injury and will void warranty.

The VOYAGER 550 and accessories must be inspected ANNUALLY by a certified technician in addition to the daily and other periodic visual checks done by the user specified in this section.

Preventive maintenance specified in this manual can prevent accidents and reduce repair costs.

Note all service or repairs to the VOYAGER 550 or its accessories in the log book at the end of this manual. Have the document signed by the certified technician.

Daily Check List

THE FOLLOWING PROCEDURES MUST BE FOLLOWED BEFORE EACH USE.

- Has the battery been charged? Park the lift on the charger whenever the lift is not in use.
- Inspect the lift for any damage. If the lift casing does not look properly aligned, or there are any cracks or other damage on the lift, or any parts are missing - DO NOT USE IT. Contact your local representative to have the lift serviced.
- Inspect the visible strap for any signs of wear, frays, loose threads or other damage. If there is any evidence of damage- DO NOT USE IT. Contact your local representative to have the lift serviced.
- Inspect the sling for tears, frayed straps or loose stitching. If the sling has any of the above damage, DO NOT USE IT. Contact your local representative to have the sling replaced or repaired.
- Inspect the carry bar for any signs of cracking or damage.
- Ensure the ring and cotter pins that attach the carry bar to the strap are secure.

Inspection and Cleaning

Clean the Voyager 550 with a soft dry cloth, or a soft cloth lightly moistened with a mild detergent solution. Do not use any type of solvent that may damage the finish.

 **Do not immerse lift in water.**

To ensure a better rolling surface for the trolley wheels, clean the inside of the track every 4 months. To do so, insert a damp cloth in the opening and slide it from one end of the track to the other.

 **Always reinstall rail end stoppers (if they have been removed) after servicing.**

Strap Inspection

This equipment is built with a strap that can withstand a load of 1364 kg (3000 lbs.). Nonetheless, if this strap is damaged or shows signs of wear, the acceptable load on the strap before rupture can drop rapidly and present a danger for the patient and/or caregiver.

BHM Medical recommends thoroughly inspecting the strap every 2 months as follows:

1. Completely unwind the strap.
2. Look for any signs of wear:

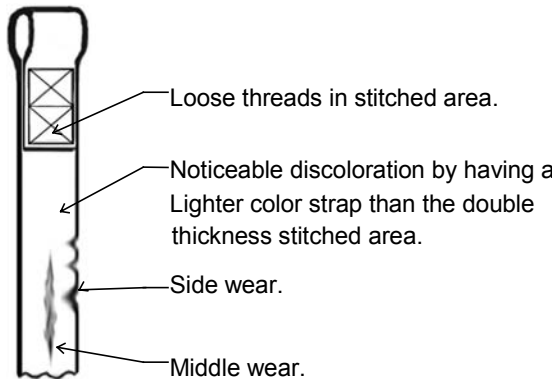



If there is any sign of wear as indicated above or any other visual defect, strap should be changed immediately. By continuing to use the lift without changing the strap, caregiver and patient safety is greatly compromised.

In any case, the manufacturer recommends changing the strap at least every two years. By continuing to use the lift without changing the strap, caregiver and patient safety is greatly compromised.

Lubrication

Even if lubrication is not mandatory, we recommend putting white grease machinery grade and NLGI 2 type on drum teeth to reduce friction once a year.

Handling and Storage

Avoid violent shock during transportation.

The lift should not remain stored for long periods of time without recharging the batteries.



BHM Medical recommends charging of batteries at least every two weeks even if the lift is not used. This will prevent premature aging of batteries.

Battery Replacement

BHM uses sealed lead-acid batteries. Contrary to nickel-cadmium, BHM batteries do not have any memory effect. Therefore, batteries should not be completely discharged before recharge.

Battery life expectancy is 3000 cycles (average of 165 pounds and 24 inches travel and 30% deep of discharge). The 3000 lift cycles represent the "half-capacity" of the battery, meaning that the battery is half of a new one. After this half-capacity, the battery will degrade rapidly. Therefore, we recommend changing for a new one.

1. Place the VOYAGER 550 on a solid table. You can use two pieces of wood to secure the unit to avoid breaking the trolley. Remove the cab from the chassis by unclipping the 4 screw caps with a small blade and use an 8 mm socket to unscrew the 4 screws.

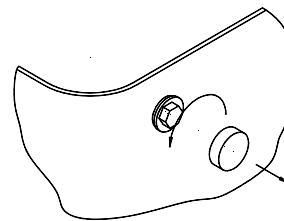

2. Unplug red/white and black/white wires from batteries. Unplug the blue jumper. Unscrew nuts (8 mm socket) which are retaining batteries support. Do not completely unscrew. Unscrew until batteries are loose.



3. Remove batteries and replace them by new batteries. Tighten nuts (8 mm socket) and plug in the blue jumper. Plug black/white and red/white wires. Be careful of the colour code (black = negative, red = positive). You can use a hot glue gun to affix the wire to the battery terminal.
4. Replace the cab. Place the cords and the handset in their respective hole. Screw back in and put on the screw caps.

Charger Fuse Replacement

If the light does not illuminate when there is a battery in it, do the following steps:

1. Check to make sure the power cord is correctly plugged into the charger in the wall.
2. Pull the power cord out of the charger. Under the socket for the power cord, there is a drawer or magazine where there are fuses. Using a pen or screwdriver, pull the drawer out gently. Pull the burned fuse out of the drawer that is next to the charger (see diagram below) and discard. Take the replacement fuse and place it in the same slot where the burned fuse was. Slide the drawer back into the charger. Plug the power cord into the charger. Place the lift onto the charger and check for the light.
3. Check the outlet to make sure it has power to it.
4. If the light does not illuminate, contact your local dealer or representative for assistance.

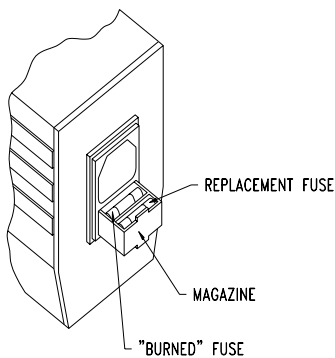

Replace the fuse with the following:

Fuse: GMC 0.5 A 250 V North America (when input is 120 Vac) Product # C8FGMC0.5

GMC 0.25 A 250 V European (when input is 240 Vac) Product # C8FGMC0.250

The fuse may also be ordered through your local dealer or representative.

Charger Fuse Replacement (for UK only)

If the light does not illuminate when there is a battery in it, do the following steps:

1. Check to make sure the power cord is correctly plugged into the charger in the wall.
2. Disconnect the power cord from the wall.
3. Unscrew the fuse holder cap.

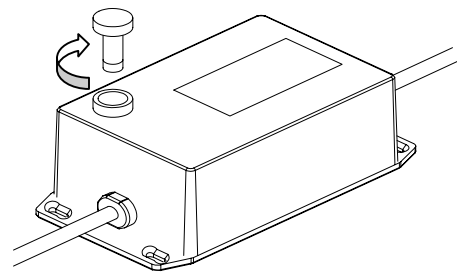

4. Replace the fuse with the following:
 Fuse: GMC 0.5 A 250 V North America (when input is 120 Vac) Product # C8FGMC0.5
 GMC 0.25 A 250 V European (when input is 240 Vac) Product # C8FGMC0.250
 The fuse may also be ordered through your local dealer or representative.
5. Screw back the fuse holder cap

Strap Replacement

1. Place the VOYAGER 550 on a solid table. You can use two pieces of wood to secure the unit to avoid breaking the trolley. Remove the cab from the chassis by unclipping the 4 screw caps with a small blade and use an 8 mm socket to unscrew the 4 screws.
2. Activate the white cord and pull the entire strap out of the drum until you align the drum screw in front of the second frame hole.

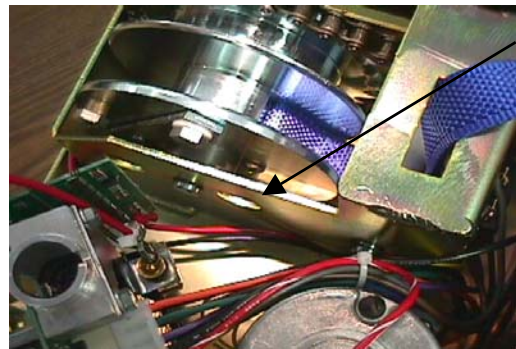

3. Unplug the 15-pin power connector from the circuit board. Remove the circuit board by unscrewing the two 5 mm screws.

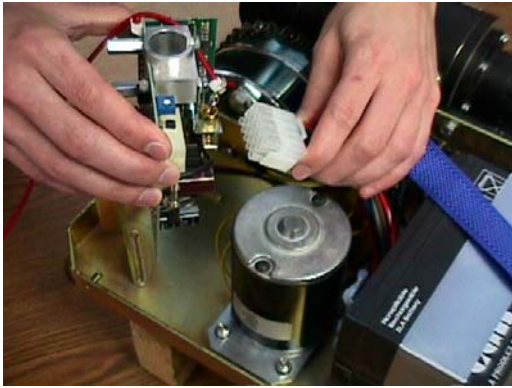

4. Find the second hole on the frame (circuit side) and unscrew the long bolt of the drum and remove the strap
5. Install the new strap in the drum (leather piece upside: wrong side can disable the limit switch functions) and screw the long bolt through the strap to the drum.

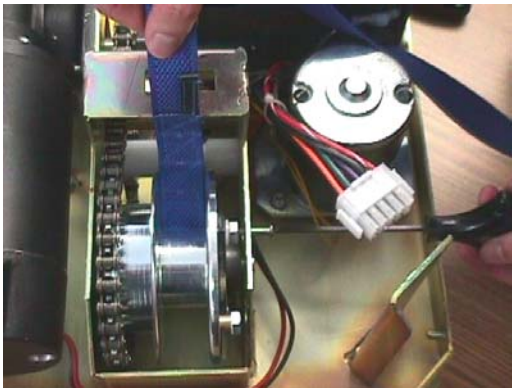

6. Unscrew nuts (8 mm socket) which are retaining batteries support and position the batteries on the frame to give you access to the limit switches.

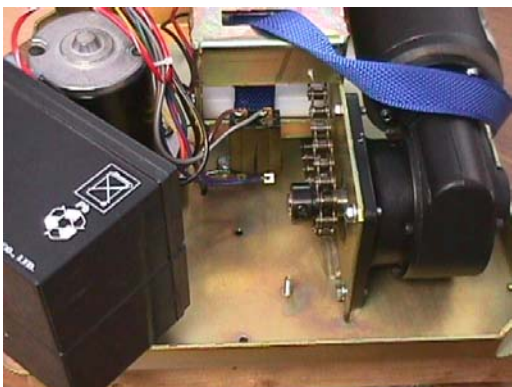

7. Insert the other end of strap through the limit switch, around the guide roll and slide it between the two limit switches and the guide roll. With one hand insert the end of strap and with the other hand using one finger push the limit switch and with another finger guide the strap through the hole.

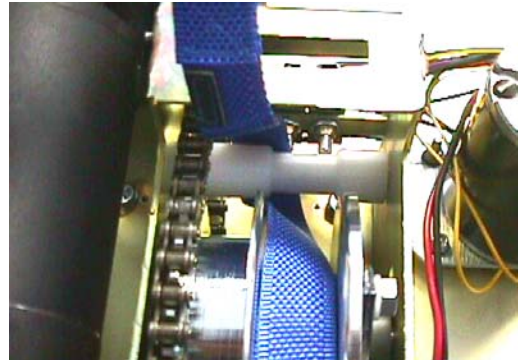

8. Put the batteries and the battery rack back in place and screw them in with the two 5 mm locknuts. Put the circuit board back in place by screwing the board to the frame with the two 8 mm screws. Plug the 15-pin power connector to the circuit board.
9. Plug in the handset and push the up button until the entire strap rolls on the drum.
10. Replace the cab. Pass the cords and handset through their respective holes. Screw back in and put on the screw caps.

NOTE: For the first use of the new strap, rewind the entire strap with light load (50 lbs.) to give a proper tension.

Drum Replacement

1. Place the VOYAGER 550 on a solid table. You can use two piece of wood to secure the unit to avoid breaking the trolley. Remove the cab from the chassis by unclipping the 4 screw caps with a small blade and use an 8 mm socket to unscrew the 4 screws.

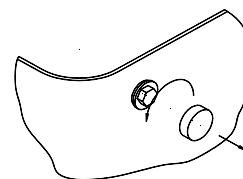

2. Pull the white cord and turn the drum until you place the connecting link of the chain at an upper position.

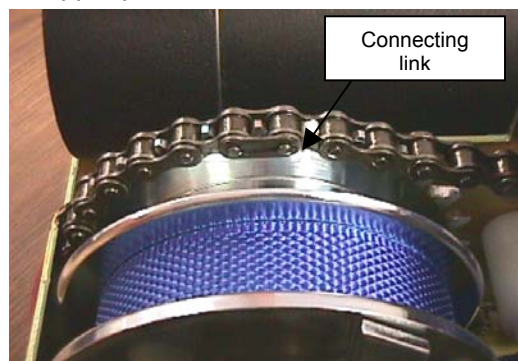

3. Unplug red/white and black/white wires from batteries. Unscrew nuts (8 mm socket) which are retaining batteries support. Remove the battery rack and the batteries.



4. Unplug the 15-pin power connector from the circuit board. Remove the circuit board by unscrewing the two 5 mm screws.

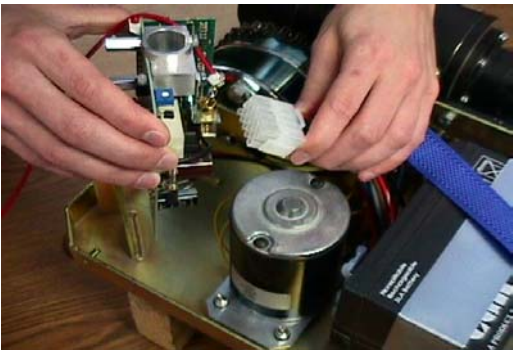

5. Remove the connecting link from the chain and leave the chain down.



6. Remove the snap ring on the center shaft of drum and pull out the shaft through the frame. Remove the drum from the frame.

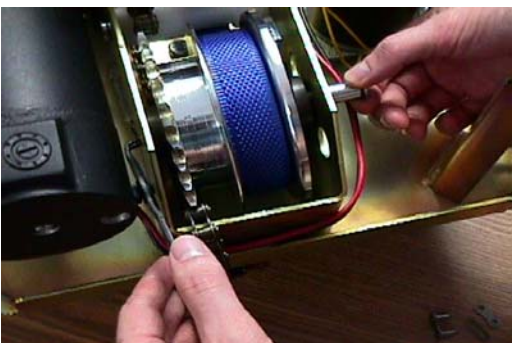

7. Install the new drum to the frame and insert the shaft through the drum and frame hole. Put the snap ring back in place.
8. Insert the end of strap through the limit switch hole. With one hand insert the end of strap and with the other hand using one finger push the limit switch and with another finger guide the strap through the hole.

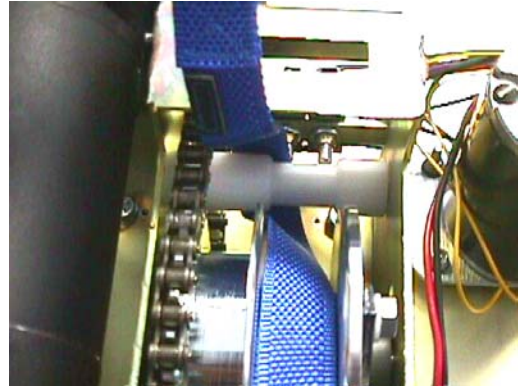

9. Install the circuit board by screwing in the two 5 mm screws. Plug the 15-pin power connector to the circuit board.
10. Replace the batteries. Tighten nuts (8 mm socket). Plug black/white and red/white wires. Be careful of the colour code (black = negative, red = positive). You can use a hot glue gun to affix the wire to the battery terminal to prevent against vibration.
11. Replace the cab. Pass the cords and the handset through their respective holes. Screw back in again and put on the screw caps.

Horizontal Motor Replacement

1. Place the VOYAGER 550 on a solid table. You can use two pieces of wood to secure the unit to avoid breaking the trolley. Remove the cab from the chassis by unclipping the 4 screw caps with a small blade; use an 8 mm socket to unscrew the 4 screws.
2. Unplug the 15-pin power connector from the circuit board. Remove the motor by unscrewing the four (4) 6 mm nuts. Unplug the motor from the 15-pin power connector with a pin extractor tool. Identify their respective positions (+) and (-).



3. Put the new motor in place. Screw the motor to the frame with the four (4) 6 mm bolts and washers. Install the 2 pin connectors
4. Install the circuit board by screwing in the two 8 mm screws. Plug the 15-pin power connector to the circuit board.
5. Replace the cab. Pass the cords and the handset through their respective holes. Screw it back on and put on the screw caps.

Vertical Motor Replacement

1. Repeat steps 1 to 5 from the **drum replacement** instructions except do not remove the circuit board.
2. Unplug the motor. Remove the motor by unscrewing the four (4) 6 mm bolts.

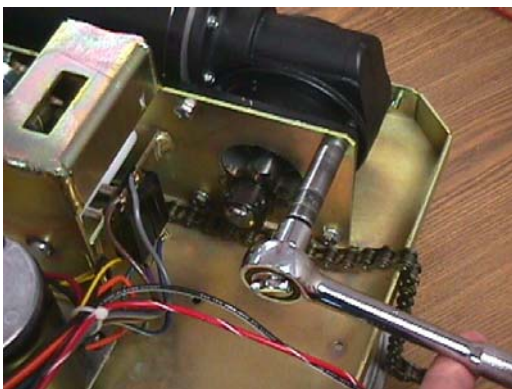

3. Pull the motor out with the sprocket assembly. Do not separate the sprocket from the motor. In case of sprocket replacement, Unscrew the screw with a 1/8 hexagonal key and gently pull out the drive from the motor
4. shaft by sliding it out.
5. Insert the new motor and screw in it with the two (2) screws at the bottom. Align the upper screw and secure it in place. Tighten the 2 other screw.
6. Replace the cab. Pass the cords and the handset through their respective holes. Screw back in and put on the screw caps.

Limit Switch Replacement

(For models before serial number ABL2-*F*-1644)

1. Repeat 1 and 5 from the **drum replacement** instructions.
2. Unplug the 15-pin power connector from the circuit board. Remove the retaining ring on the center shaft of strap guide roll and pull the shaft out through the frame. Pull out the strap guide roll from the frame.
3. Remove the strap guide roll with the center shaft and snap ring.



4. Remove the limit switch by unscrewing the 1/2 in. nut.

5. Unpin the limit switch from the 15-pin connector and replace by the new one.
6. Put the strap guide roll in place with the center shaft and snap ring.
7. Plug the 15-pin power connector to the circuit board. Replace the cab. Pass the cords and the handset through their respective holes. Screw back in and put on the screw caps.

(For models after serial number ABL2-*F*-1644)

1. Repeat 1 and 2 from the **horizontal motor replacement** instructions.
2. Unplug, in order, the purple, blue and gray wires from the limit switch.

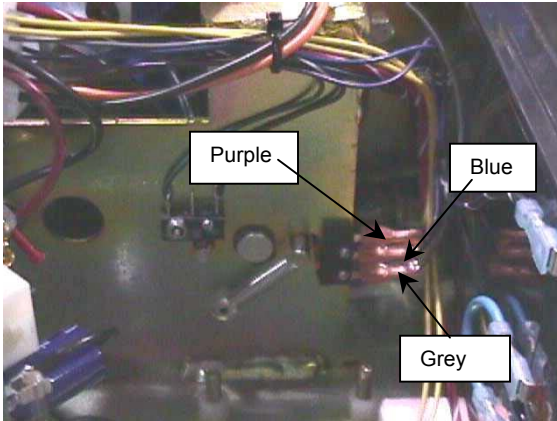

3. Unscrew the 2 screws with a flat tip screwdriver and the appropriate key.



4. Remove the limit switch and replace it by a new one.
5. Screw back in the 2 screws of the new limit switch.
6. Plug back, in order, the purple, blue and grey wires.
7. Put the horizontal motor in place. Screw the motor to the frame with the four (4) 6 mm bolts and washers. Install the 2 pin connectors.
8. Install the circuit board by screwing in the two 8 mm screws. Plug the 15-pin power connector to the circuit board.
9. Replace the cab. Pass the cords and handset through their respective holes. Screw it back on and put on the screw caps.

Limit Switch Rod Replacement

1. Repeat 1 and 2 from the **horizontal motor replacement** instructions.
2. Repeat step 1 to 3 from the **vertical motor replacement** instructions.

3. Drill out the rivet that holds the limit switch rod.
4. Remove the spring that holds the rod.

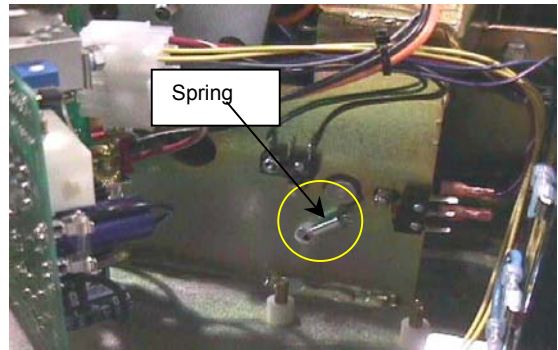

5. Pull out the limit switch rod.
6. Insert the new rod and hold in place by popping the rivet as shown in the diagram below.

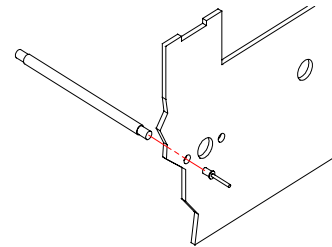

7. Put the spring back on.

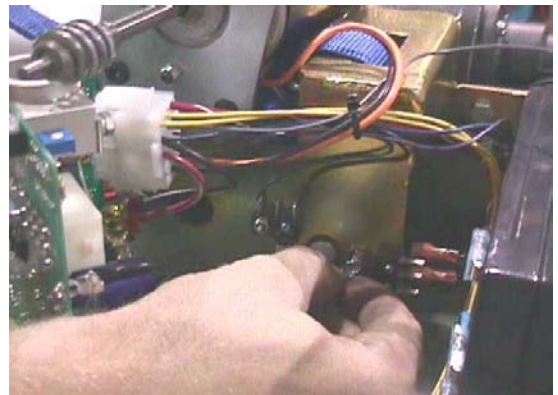

8. Insert the vertical motor and screw in it with the two (2) screws at the bottom. Align the upper screw and secure it in place. Tight the 2 other screws.
9. Put the horizontal motor in place. Screw the motor to the frame with the four (4) 6 mm bolts and washers. Install the 2 pin connectors.
10. Install the circuit board by screwing in the two 8 mm screws. Plug the 15-pin power connector to the circuit board.
11. Replace the cab. Pass the cords and handset through their respective holes. Screw it back on and put on the screw caps.

MAINTENANCE INSPECTION CHECKLIST

Maintenance Inspection Checklist

THING TO BE INSPECTED BY USER

ITEM	INITIALLY	BEFORE EVERY USE	EVERY 2 MONTH	EVERY 6 MONTH	EVERY YEAR	EVERY 2 YEARS
LIFT DEVICE						
Inspect for missing hardware or broken panel.	X	X			X	
Inspect strap for wear.		X	X			
Recharging battery		X				
Inspect trolley in rail for damage, rust or cracks. Replace if damaged.					X	
Overall inspection by authorized personnel.					X	
SLINGS AND HARDWARE						
Check all sling attachments for sign of wear.		X				
Inspect sling material for wear or deterioration.		X				
Inspect sling straps for wear.		X				
Inspect for any defect or loose threads in the "stitched areas".		X				
Cleaning sling as indicated on the tag.	<i>When Necessary</i>					
Verify strap extension for wear. Check stitching and check for degradation due to chemical attack				X		
Verify emergency stop cord for wear.				X		
Verify emergency lowering cord for wear.				X		
Replace strap.						X
Completely unwind the strap and check stitching and fraying and check for degradation due to chemical attack.				X		
Check the carry bar for freedom of rotation.				X		
Check for wear on the central pivot of the carry bar and lubricate it with any light, mineral based grease.				X		
Inspect carry bar connecting joint for proper attachment.				X		
Check for presence and correct fitting of the split rings on the carry bar.				X		
Inspect for excessive wear on the sling hooks and any side suspenders used in conjunction with the spreader bar.				X		
Check for adequate padding of the carry bar.				X		
Inspect sprockets and chain for wear.				X		
Lubricate chain and sprockets.				X		
Inspect trolley wheels for damage, carrying or rust. Check also the wear on the axles and check for firm attachment.				X		

MAINTENANCE INSPECTION CHECKLIST

ITEM	INITIALLY	BEFORE EVERY USE	EVERY 2 MONTH	EVERY 6 MONTH	EVERY YEAR	EVERY 2 YEARS
Inspect the welding aspect on the frame to detect cracks.				X		
Inspect connecting joints for proper attachment.				X		
Confirm the correct operation of the emergency brake by making sure it is moving freely on the drum.				X		
Confirm correct function of the mechanical emergency lower.				X		
Check for firm fixing of the charger to the track.				X		
Confirm correct mating of the lift to the charger.				X		
Confirm correct functioning of the charger.				X		
Check corrects fuse rating.				X		
Check mains lead plug and socket for proper mating, look for damage, evidence of burning or arcing.				X		
Inspect "Quick Release" system for wear.				X		
Load test with the SWL (maximum capacity).				X		



Maintenance inspection points are suggested by the manufacturer. However, in certain case, some inspections should be done on a more frequent basis. By continuing to use the lift without replace the listed parts in this maintenance, caregiver and patient safety is greatly compromised.

TROUBLESHOOTING



ELECTRICAL SHOCK HAZARD – Before checking electrical components, remove fuses, unplug the device or disconnect battery.

CAUTION: HIGH VOLTAGE FROM TEST EQUIPMENT can damage electronic circuit and other parts.

What might seem to be a power failure is not always the case. First check the following:

PROBLEMS	TO CHECK
The unit starts and stops repetitively	<ul style="list-style-type: none"> • If the load is over the safe working load, the unit will not work due to an overload protection on the motor. • Has the lift been making a “beeping” sound? The battery is low and needs to be charged.
The lift emits a “beep” and a red light flashes during utilisation. The unit may stop lifting but you can still lower it.	<ul style="list-style-type: none"> • Batteries are low, return to charger.
Charge indicator on the lift (green-red) doesn't light up when the lift is on the charger	<ul style="list-style-type: none"> • Is the charger stopper plugged into a standard outlet? If so does the outlet have power? • Check the condition of the fuse. If needed, change it with a spare one. (see “Maintenance” section of this manual)
Battery is always dead after a few transfers. (3 to 5)	<ul style="list-style-type: none"> • Replace battery with a new one, the life of the current one is probably nearly over. (Contact your local dealer or representative to have battery replaced)
The light on the charger shows green yet the lift will only do one or two transfers.	<ul style="list-style-type: none"> • Contact your local dealer or representative to have battery replaced.
The light on the charger shows green yet the lift will only work when there is no one in the lift. When you attempt to transfer someone, the lift stops.	<ul style="list-style-type: none"> • Contact your local dealer or representative to have battery replaced.
The lift does not work when you press the buttons on the handset	<ul style="list-style-type: none"> • Is the charger light on? Lift must be moved away from the charger in order to operate. • Is the emergency stop activated? Gently pull the red cord once until you hear a ‘click’. Try the buttons again. • Is the handset properly plugged into the lift? The handset may be slightly pulled out of its socket yet appear as though it is plugged in. The lip of the handset must be flush with the cab of the lift. The socket and handset connector is a tight fit – press firmly to ensure the handset is plugged in properly. • If the handset was not properly plugged into the lift, it may be necessary to gently pull the red cord once again. • Slide the lift over to the charger. Is the light red or not on at all? Battery likely needs to be charged. See troubleshooting situations above for more information. • If, after testing all of the above, the lift will not operate, contact your local dealer or representative.
The charging light on the lift remains red and does not turn to green after an overnight charge.	<ul style="list-style-type: none"> • If available, try another integrated charger stopper from another lift or a spare one; plug it into the rail and charge for 3 hours. If the light does not change to white or green, contact your local dealer or representative. • Using a voltage meter, test the two contact points on the

TROUBLESHOOTING

PROBLEMS	TO CHECK
	charger (see diagram T-1). The voltage meter should read between 26-30 volts AC. <ul style="list-style-type: none">• Contact your local dealer or representative.
When you press the button to return the lift to its charger (4 way motors only), the lift goes to the charger but does not lower the carry bar and you can hear a 'humming' sound.	<ul style="list-style-type: none">• Charger either does not have power or is not working properly, see troubleshooting question above.

DIAGRAM T-1

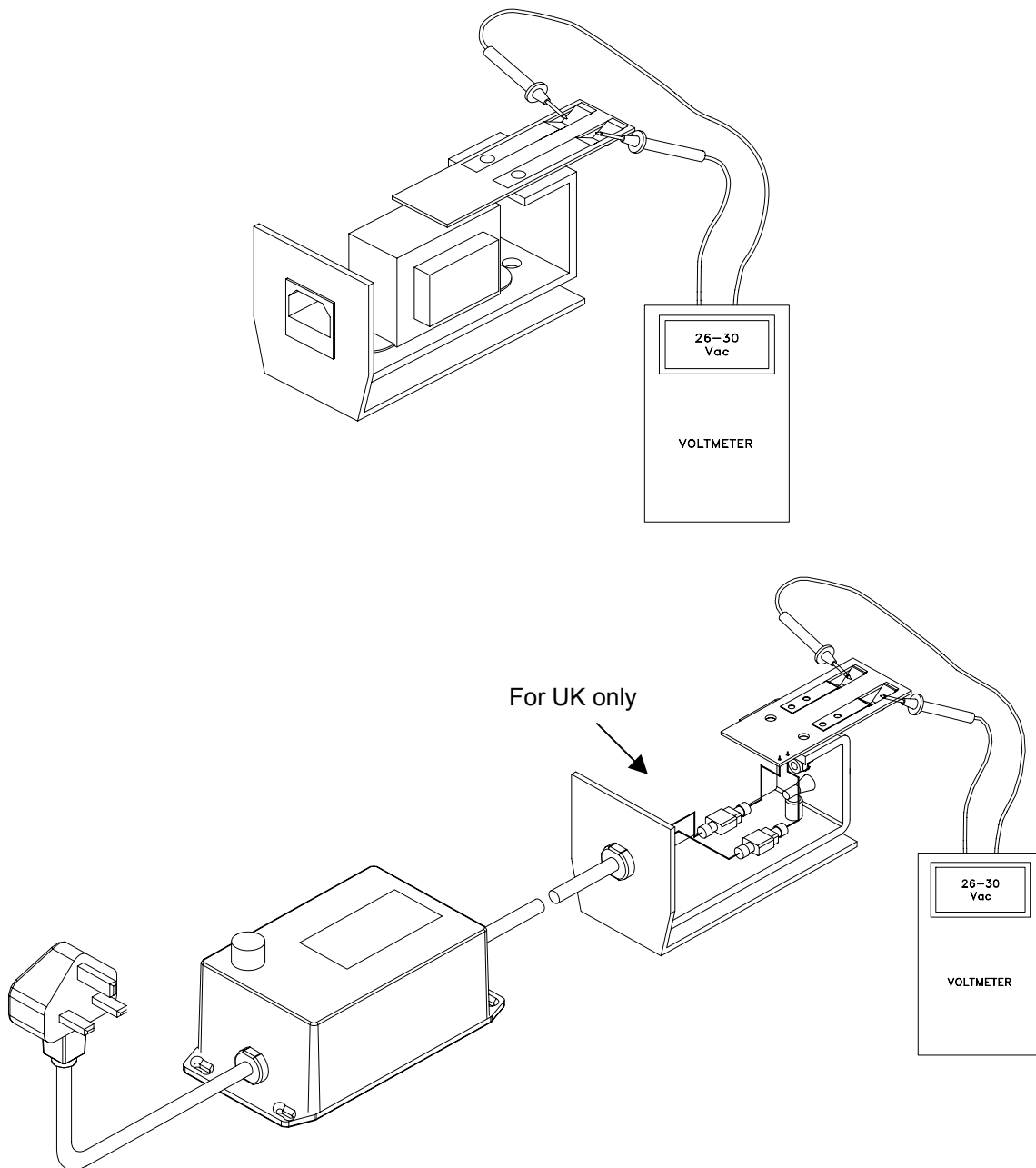

PARTS LIST

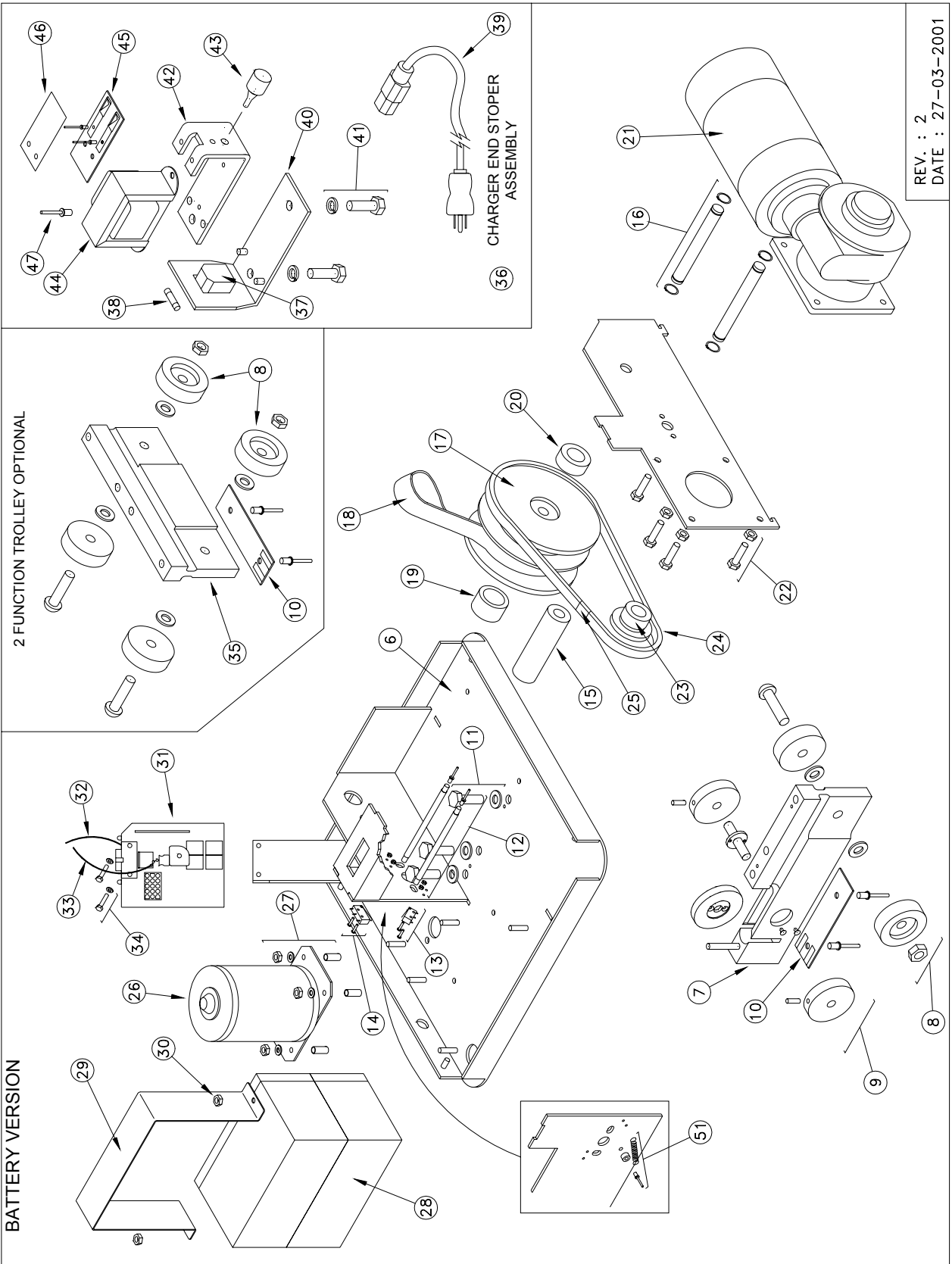

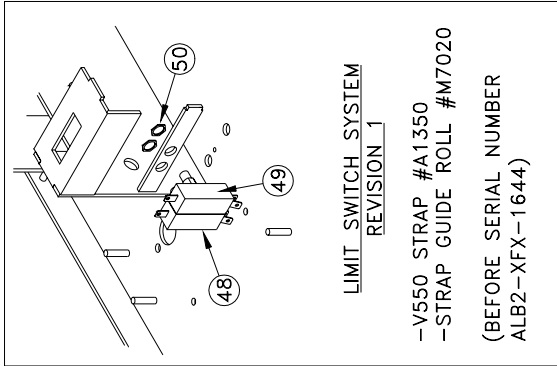
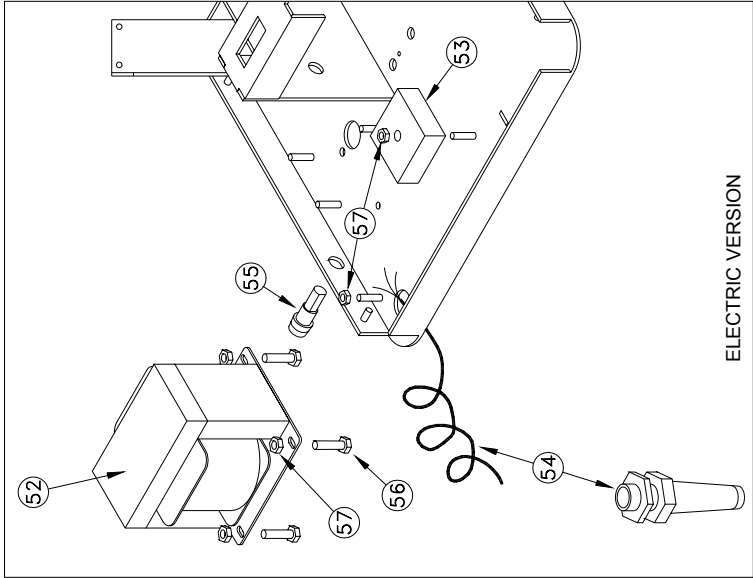

BATTERY VERSION

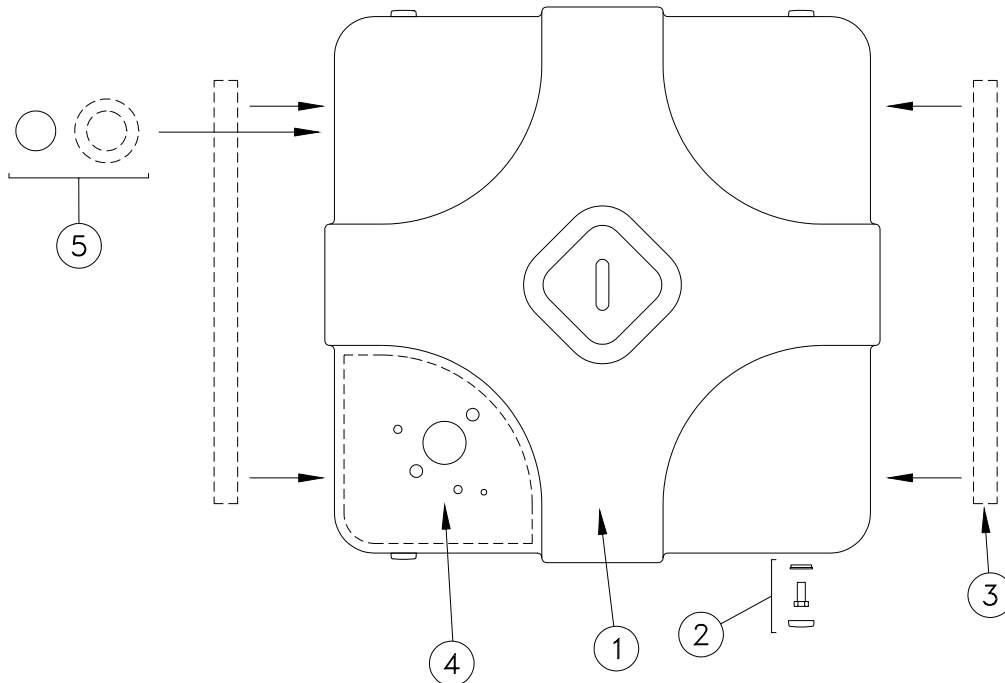

<u>ITEM NO.</u>	<u>QTY.</u>	<u>PART NO.</u>	<u>DESCRIPTION</u>
1	1	A5405	VOYAGER BATTERY CAB ASSEMBLY
2-1	4	000.02950	PLASTIC CAP M5
2-2	4	000.02550	SCREW M5 X 12 HEX
2-3	4	000.02955	PLASTIC WASHER M5
3	2	P5002	VOYAGER 550 LABEL
4	1	P5010	V550 DISPLAY LABEL
5-1	1	P5030	EMERGENCY LOWERING LABEL
5-2	1	000.01038	PLASTIC CAP
6	1	M5000	V550 FRAME
7	1	A5220-A2	4 FONCTION TROLLEY ASSEMBLY
7*	*1	M5220	4 FONCTION TROLLEY ALUMINIUM PART ONLY
8-1	1	000.04260	M10 X 40mm SCREW
8-2	2	A5245	50mm WHEEL ASSEMBLY
8-3	2	000.04430	10mm WASHER
8-4	1	000.04418	M10 JAM NUT
9-1	2	M5240	50 mm TRACTION WHEEL
9-2	2	000.02600	SET-SCREW M5 X 25
9-3	1	M5210	TRACTION SHAFT
9-4	1	M5200	WORM GEAR
9-5	1	000.02000	M3 x 5 FLAT SCREW
10	1	A5160	CIRCUIT CONTACT ASSEMBLY (4F)
10-1	2	000.00887	POP RIVET 1/8 X 3/8

PART LIST

<u>ITEM NO.</u>	<u>QTY.</u>	<u>PART NO.</u>	<u>DESCRIPTION</u>
11-1	3	000.03635	M8 X 20 HEX SCREW
11-2	3	000.03960	M8 LOCKWASHER
12-1	2	000.00887	POP RIVET
12-2	2	200.05095	LIMIT ROD
13-1	1	460.00005	SWITCH DB2
13-2	2	000.00005	2-56 BOLT
13-3	2	000.00022	2-56 LOCKNUT
13-4	1	460.00015	SWITCH BLADE
14-1	1	460.00005	SWITCH DB2
14-2	2	000.00005	2-56 BOLT
14-3	2	000.00022	2-56 LOCKNUT
15	1	200.07020	STRAP GUIDE ROLL
16-1	2	M5065	12mm X 100 STEEL SHAFT
16-2	4	000.00850	SNAP RING 12mm
17	1	A5060	DRUM ASSEMBLY WITH STRAP
18	1	A1351	V550 STRAP ONLY
18*	1	A1350	V550 STRAP ONLY
19	1	M10055	SPACER DRUM (BREAK SIDE)
20	1	M10060	SPACER DRUM (SPROCKET SIDE)
21	1	A5000	VERTICAL MOTOR ASSEMBLY
22-1	4	000.03095	M6 X 16 HEX SCREW
22-2	3	000.03420	M6 LOCKWASHER
23	1	000.01162	1 SPROCKET 41BS9 (INCLUDE IN ITEM 21)
24	1	000.01176	#41 CHAIN
25	1	000.01190	#41 CONNECTING LINK
26	1	A5100	HORIZONTAL MOTOR ASSEMBLY
27-1	4	000.02800	M5 LOCKNUT
27-2	4	000.02905	M5 FLAT WASHER
27-3	4	000.02940	GROMMET RUBBER
27-4	4	000.02537	5 X 10 NYLON SPACER
28	2	E0150	12V 7Ah BATTERRIES
29	1	M5020	BATTERRIES RACK
30	2	000.02800	M5 LOCKNUT
31	1	E5500-4FB	BHM-03 CIRCUIT BOARD
31*	1	C6SPC6A	PULL CHAIN REPLACEMENT
31*	1	C5CUMNL/P15	15 PINS CONNECTOR PLUG
32	1	000.01344	WHITE CORD
33	1	000.01343	RED CORD
34-1	2	000.02550	M5 X 12 HEX. SCREW
34-2	2	000.02900	M5 LOCKWASHER
35*	***1	A5235	2 FONCTION TROLLEY ASSEMBLY (OPTIONAL)

<u>ITEM NO.</u>	<u>QTY.</u>	<u>PART NO.</u>	<u>DESCRIPTION</u>
35*	***1	M5235	2 FONCTION TROLLEY ALUMINIUM PART ONLY
36	1	A5300	CHARGER END STOPPER ASSY
37*	***1	C5CBUL/MF-C3	BULGIN 3mm 100-120V
37*	***1	C5CBUL3MM220	BULGIN 3mm 220-240V
38*	***2	C8FGMC0.5	FUSES GMC 0.5A
38*	***2	C8FGMC0.250	FUSES GMC 0.250A
39*	***1	E7525	1.5m. POWER CORD NORTH AMERICA
39*	***1	E7528	2.5m. POWER CORD AUSTRALIA
39*	***1	E7521	2.5m POWER CORD EUROPE
39*	***1	E7529	2m POWER CORD JAPAN
39*	***1	E7527	2.5m. POWER CORD U.K.
40	1	M5310	CHARGER ATTACHMENT
41-1	2	000.03675	SCREW M8 x 25 HEX
41-2	2	000.03960	LOCKWASHER M8
42	1	M5300	CHARGER END STOPPER FRAME
43	1	Q1028	RUBBER BUMPER
44*	***1	E7510	100-120/24V 50VA TRANSFORMER
44*	***1	E7517	220-240/24V 50VA TRANSFORMER
45	1	A5300	CHARGER CONTACT ASSY
45-1	1	C9BHM34	CONTACT BOARD
45-2	2	200.05340	CONTACT BLADE
45-3	2	000.00888	POP RIVET 1/8 x 1/8
46	1	200.05345	MICA PROTECTOR
47	5	000.00895	RIVET 3/16 x 1/8-1/4
48	1	A5155	LOW LIMIT ASSEMBLY
49	1	A5150	HIGH LIMIT ASSEMBLY
50	2	000.00407	NUT 3/8-32
51-1	1	000.00873	6.5 X 25mm SPRING
51-2	1	000.02535	5 X 5mm NYLON SPACER
51-3	1	000.00895	RIVET 3/16 x 1/8-1/4
52*	***1	E7250	120/24V 350VA TRANSFORMER
52*	***1	E7251	220/24V 350VA TRANSFORMER
53	1	C1PMB256	BRIDGE RECTIFIER 25A 600V
54*	***1	A7190	120/24V COIL CABLE 12-110V
54*	***1	A7195	240/24V COIL CABLE 12-220V
55	1	C8FHBB	FUSE HOLDER IN-LINE HBB
56	4	000.02500	SCREW M5 X 12 HEX
57	6	000.02800	M5 LOCKNUT

*** SELECT CURRENT ACCORDING TO COUNTRY

OTHER PARTS

8 BUTTON HANDSET	A5600	2 BUTTON HANDSET	A0093
FUSE 0.5 AMPS	C8FGMC0.5	FUSE 0.25 AMPS	C8FGMC0.25
FUSE 4 AMPS	C8FGMA4	FUSE 15 AMPS	C8FGMA15
AMP PIN EXTRACTING TOOL	318851-1		

ACCESSORIES

INTEGRATED CHARGER STOPPER
Product No. A5300

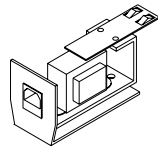

RAIL STOPPER
Product No. A5320

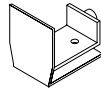

CHARGER STOPPER FOR UK ONLY
Product No. 700.05235.04

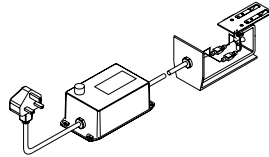

CARRY BAR
Product No. A5465

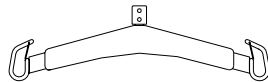

ERGOSCALE WEIGHING DEVICE
Product No. ERGOSCALE-T2

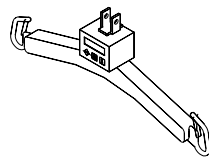

INFRARED REMOTE CONTROL
Product No. A5400
(must be ordered with lift)

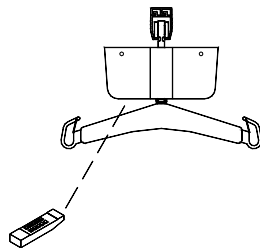

TIMER FOR RETURN TO CHARGE
Product No. A5200



SUPPORT FOR ERGOFIT PLUS SLING
Product No. 700.05550

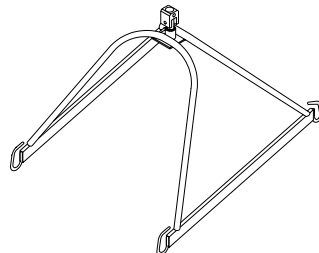

TRAPEZE BAR
Product No. A5700

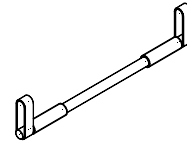

SUPPORT FOR SOFT STRECHER SLING
Product No. A5515

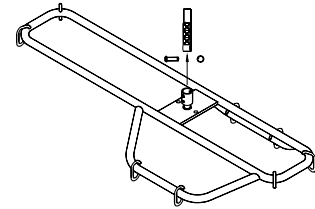

FUSE
Product No.
C8FGMC0.5 (120/24 volt) North America
C8FGMC0.25 (240/24 volt) European

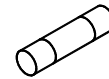

SEMI PERMANENT RACK
Product No. A9200

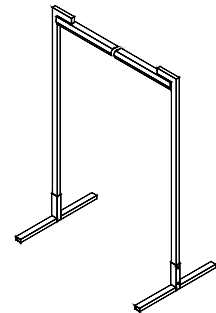

HOSPITAL GRADE POWER CORD
Product No. E7525 North America
E7521 Europe
E7527 UK
E7528 Australia

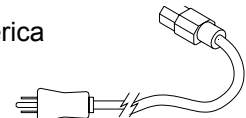

HANDSET
2-button Product No. E0093
For VOYAGER 420 and 550
2 functions

6-button Product No. A0086
For VOYAGER 420 and 800
4 functions

8-button Product No. A5600
For VOYAGER 550
4 functions



WARRANTY

This warranty is extended only to the original purchaser/user of BHM products.

BHM Medical Inc. warrants its products to be free from defects in material under normal use and service, within the periods stated below from the date of purchase. If within such warranty period any such product shall be proven to be defective, such product shall be repaired or replaced at BHM Medical's option. This warranty does not include any labor or shipping charges incurred in replacement part installation or repair of any such product. BHM Medical's sole obligation and your exclusive remedy under this warranty shall be limited to such repair and/or replacement.

Patient Lifter	1 year
Tracks and installation	Life time warranty*
Weighing Devices	1 year
Accessories on Lifter	1 year
Slings	1 year
Batteries - Voyager Portable	3 months
Batteries - All other lifts	1 year
Easytrack System	1 year

For warranty service, please contact the dealer from whom you purchased the BHM Medical product. [In the event that you do not receive satisfactory warranty service, please contact BHM Medical (see contact information in Table of Contents).]

Do not return products to our factory without prior authorization. BHM Medical will issue a Return Merchandise Authorization (RMA) Number. C.O.D. shipments will be refused; all shipments to BHM Medical must be prepaid. For this warranty to be valid, the purchaser must present its original proof of purchase at the moment of the claim. The defective unit, assembly or part must be returned to BHM Medical for inspection. The part or components repaired or replaced are guaranteed for the remaining period of the initial warranty.

Limitations and Exclusions:

The warranty above does not apply to serial numbered products if the serial number has been removed or defaced.

No warranty claim shall apply where the product or any other part thereof has been altered, varied, modified, or damaged; either accidentally or through improper or negligent use and storage. Warranty does not apply to products modified without BHM Medical's express written consent, (including but not limited to products modified with unauthorized parts or attachments); products damaged by reason of repairs made to any component without the specific consent of BHM Medical, or to products damaged by circumstances beyond BHM Medical's control. BHM Medical will solely determine evaluation of warranty claim. The warranty does not apply to problems arising from normal wear or failure to adhere to the instructions in this manual. BHM Medical Inc. slings are void of warranty if not laundered as per instructions on the Sling Label.

BHM Medical Inc. shall not be liable for damages losses or inconveniences caused by a carrier.

This warranty replaces any other warranty expressed or implicit and constitutes BHM Medical Inc. only obligation towards the purchaser. BHM Medical shall not be liable for any consequential or incidental damages whatsoever.

* Valid only if BHM Medical did the original installation. Warranty void if tracks/installation have been modified.